

Part Number	500 - 800 <i>ResQu</i> system Reset button	CE
Description	Disabled Alarm System Reset Button	
Reference	Installation Guidelines – T2/DAR/install/24-09-06	

Overview

- Low Profile RESET BUTTON for use in Disabled Toilet alarm systems.
- Printed with wheelchair symbol.
- Normally open contacts (push to make).
- Lightweight easy fit enclosure supplied with backbox



General Installation

The unit is normally mounted within the disabled toilet area, within reach of the toilet. Cable can be the normal security type (only two cores are required). The unit is supplied with a low profile backbox but can also be mounted on a flush plasterboard backbox.

PCB Connections

This application shows how to connect the Reset button to a *ResQu* alarm system. Several buttons can be installed all wired across the **GND** and **Reset IP** terminals of the main panel.

ResQu Control Panel
Terminals



PCB View

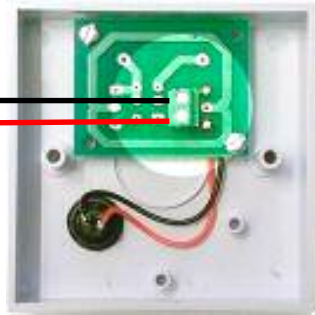

Circuit Diagram of two switches

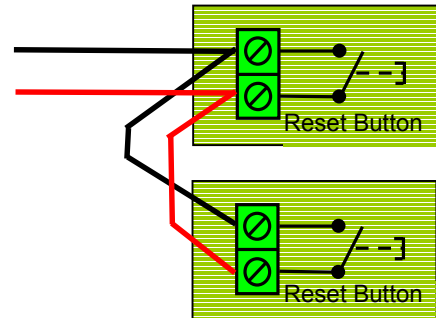

Technical Data				CE
Input Voltage:	10 to 32VDC	Dimensions:	W.87mm x L.87mm x H.38mm	
Temperature Range:	-20 to +70°C	Material	FR ABS	